

ROTATORI MECCANICI

I - Rotatori meccanici

GB - Mechanical rotors

D - Mechanische Drehmotoren

F - Rotateurs mécaniques

E - Rotores mecánicos

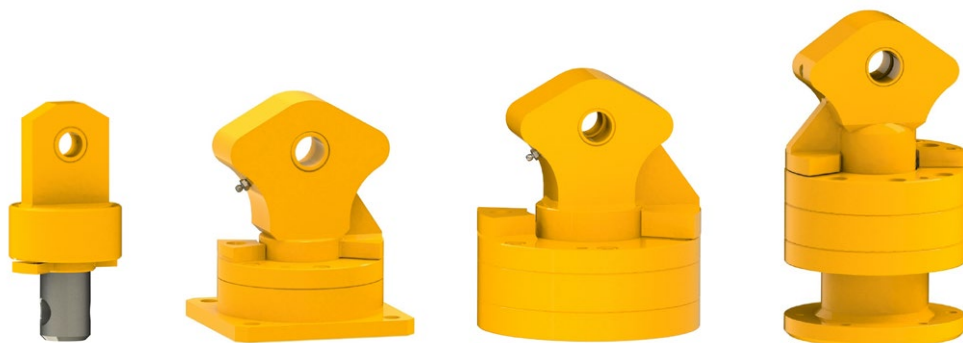

DISEGNO TECNICO / TECHNICAL DRAWING

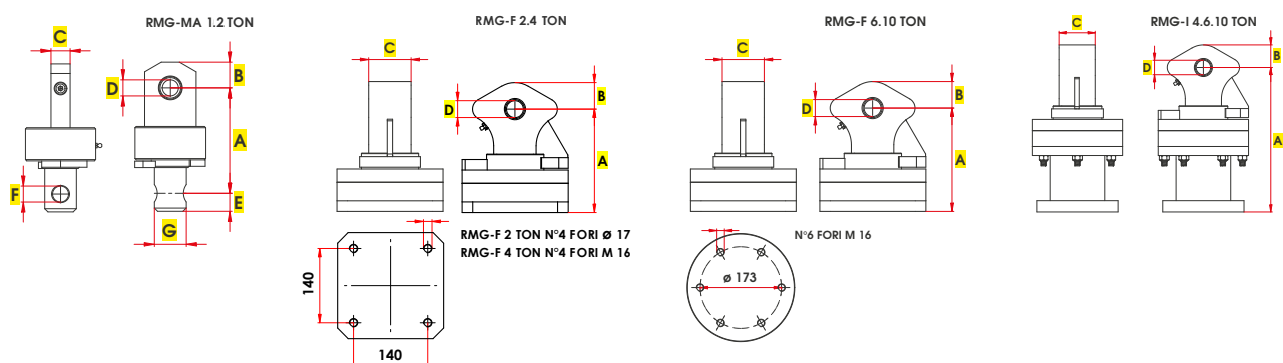

Modello Type	Portata Load	Peso Weight	Rotazione Rotation	A	B	C	D	E	F	G
	kg	kg		mm	mm	mm	mm	mm	mm	mm
RMG-MA	1	7	250°	166	38	30	25	28	25	49,5
RMG-MA	2	17	250°	210	50	60	30	28	30	59
RMG-F	2	19	250°	175	50	60	30	-	-	-
RMG-F	4	33	250°	200	50	80	30	-	-	-
RMG-I	4	40	250°	320	50	80	32	-	-	-
RMG-F	6	42	250°	215	50	80	32	-	-	-
RMG-I	6	53	250°	330	50	80	32	-	-	-
RMG-F	10	90	250°	300	70	100	50	-	-	-
RMG-I	10	108	250°	400	70	100	50	-	-	-

MA = Massello+Albero - Steel lump + shaft

F = Flangiato - Flanged

I = Incasso - Integrated